

W. J. SOMERWILL.

TOY BANK.

APPLICATION FILED JULY 13, 1904.

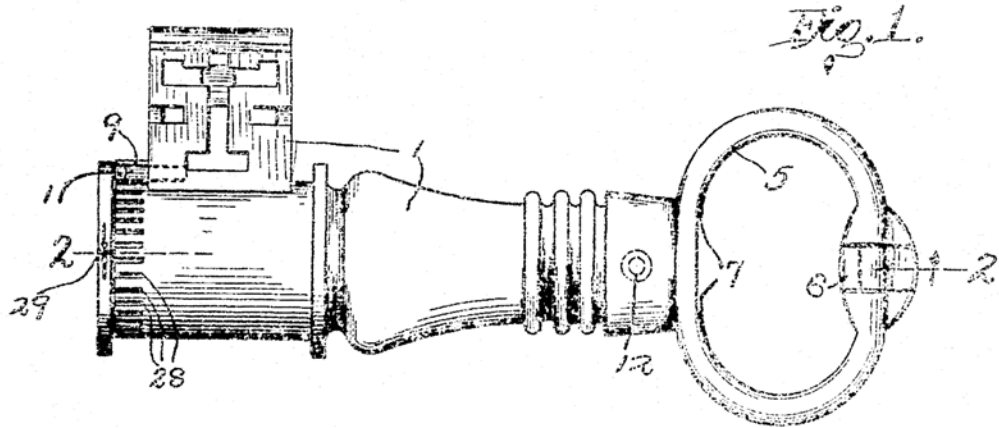

Fig. 1.

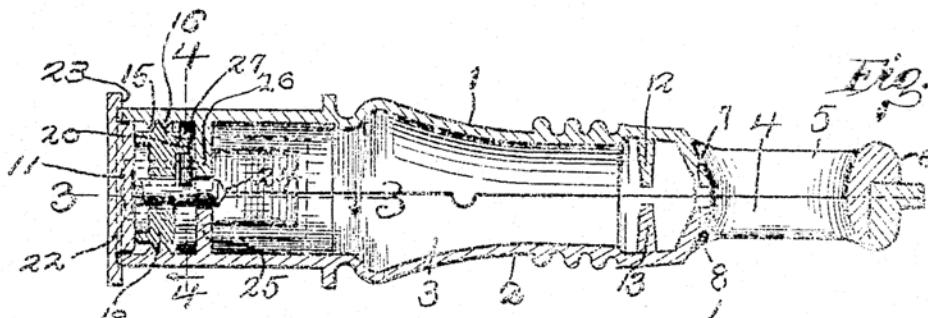

Fig. 2.

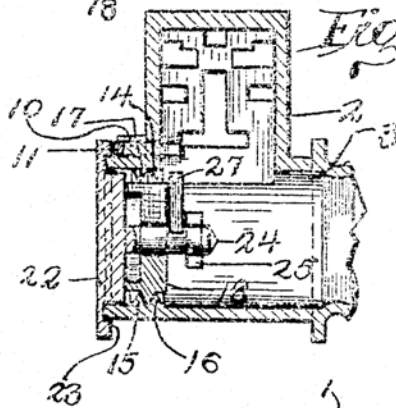

Fig. 3.

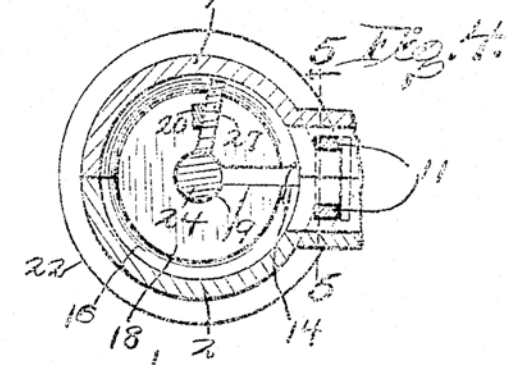

Fig. 4.

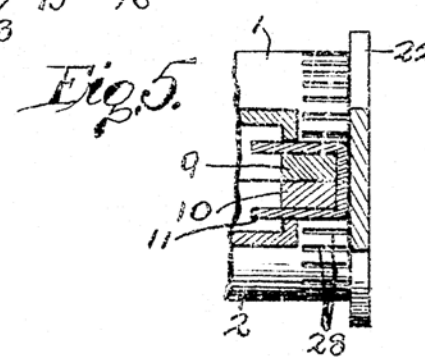

Fig. 5.

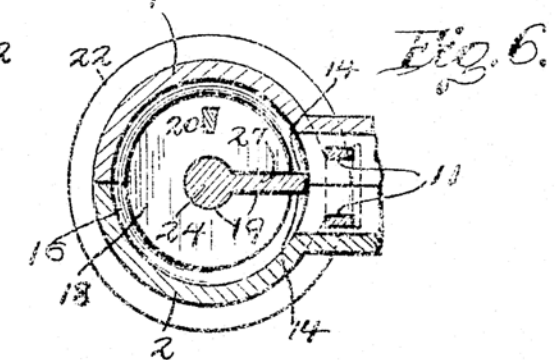

Fig. 6.

WITNESSES:

Daniel E. Raby.
Victor C. Lynch.

INVENTOR

William J. Somerwill
BY
Lynch & Over
ATTORNEYS.

UNITED STATES PATENT OFFICE.

WILLIAM J. SOMERWILL, OF CLEVELAND, OHIO.

TOY BANK.

SPECIFICATION forming part of Letters Patent No. 786,689, dated April 4, 1905.

Application filed July 13, 1904. Serial No. 216,389.

To all whom it may concern:

Be it known that I, WILLIAM J. SOMERWILL, a citizen of the United States of America, residing at Cleveland, in the county of Cuyahoga and State of Ohio, have invented certain new and useful Improvements in Toy Banks; and I hereby declare the following to be a full, clear, and exact description of the invention, such as will enable others skilled in the art to which it pertains to make and use the same.

This invention relates to improvements in toy banks.

The object of this invention is to provide a bank which can be cheaply constructed, easily assembled, and which will afford a safe receptacle for coins, while having means for allowing the ready removal of the coins from the bank when desired by the owner thereof.

Toy banks as commonly constructed consist of two or more members, generally of cast-iron, which are secured together by a fastening device, so as to form a receptacle for the coins, and when it is desired to use the coins the fastening device is removed and the members are separated.

My invention therefore consists in providing a fastening device for securing together the members which form the bank and also a guard device which prevents the fastening device from being removed and the members from being separated while said guard device is in its operative position.

My invention further consists in providing new and improved locking means for securing the guard device in its operative position.

My invention also consists in the features of construction and combination of parts, as described in the specification, pointed out in the claims, and illustrated in the drawings.

In the accompanying drawings, Figure 1 shows an exterior view of a toy bank embodying my invention, which in this particular construction is made in the form of a key. Fig. 2 is a section on line 2 2, Fig. 1. Fig. 3 is a section on line 3 3, Fig. 2. Fig. 4 is a section on line 4 4, Fig. 3. Fig. 5 is a section on line 5 5, Fig. 4. Fig. 6 is a similar view to Fig. 5, showing guard device unlocked.

Again referring to the drawings, 1 and 2 represent two members or castings which together form the bank or receptacle for the coins. These members 1 and 2 are provided at their upper ends with rings 4 and 5, respectively, and at the top of the ring 4 is formed a hook-shaped lug 6, which engages with the ring 5, so as to hold the receptacle together at its upper end. Grooves 7 and 8 are formed in the respective members 1 and 2 and are arranged to register with each other when the members are placed together, so as to form a slot through which the coins can be inserted. In the exterior surface, near the lower end of the members 1 and 2, are formed lugs 9 and 10. A fastening device consisting of a U-shaped clip 11 is arranged to embrace said lugs 9 and 10, so as to secure the receptacle together at its lower end. On the interior surface of the receptacle 3 are arranged lugs 12 and 13 in line with each other, which are designed to act as deflectors for turning the coins transversely of the slot when the bank is tipped so as to bring the coins in proximity to the slot. Near the lower end of the receptacle 3 are formed annular ridges 15 and 16, in which are formed openings 17 and 14, respectively. Between the ridges 15 and 16 is arranged a plate 18 so as to turn freely in the groove formed by the said ridges. In the plate 18 is formed a slot or opening 19, and on the upper or inner face thereof is formed a lug 20. At the bottom of the receptacle is arranged a guard 22, which is provided with an annular flange 23, which embraces the lower end of said receptacle and serves to lock the members 1 and 2 together. To the center of the guard 22 is secured a small shaft 24, which is arranged to extend up into the receptacle 3, and its inner end is supported between lugs 25 and 26, formed on the interior surface of said receptacle. To the shaft 24 is secured a pin or tumbler 27 in proximity to the upper surface of the plate 18, so that when the guard 22 is turned the said tumbler will come in contact with the lug 20 on the said plate 18. Around the lower end of the receptacle are formed a series of marks or graduations 28, and on the rim of the guard 22 is formed a mark or pointer 29.

The operation of the bank is as follows: The members of the bank are secured together by a clip 11, and the plate 18 is turned so that the opening 19 registers with the small openings 14 and 17 in the ridges 16 and 15, respectively. The guard 22 is then secured to the bottom of the bank by inserting the shaft 24 and the tumbler 27 through the opening 19 in the plate 18 and through the openings in the ridges 15 and 16, and the guard is then turned so that the tumbler is brought into contact with the lug 20 on the plate 18, thereby rotating the plate 18 and moving the opening 19 out of registration with the openings 14 and 17 in the said ridges, and the bank cannot be opened by one not knowing the combination. When it is desired to open the bank, the guard 22 is turned until the pointer 29 thereon registers with one of the graduations 28, the exact one depending on the location of the pointer on the guard, and while the guard 22 is being turned to bring the said pointer in registration with the proper graduation the tumbler 27 will engage with the lug 20 and rotate the plate 18, so as to bring the opening 19 in registration with the openings 14 and 17 on the ridges 16 and 15, respectively. The guard 22 is then turned in the opposite direction until the pointer 29 again registers with another predetermined graduation 28, when the tumbler 27 will register with the opening in the plate 18 and can be withdrawn through the said slot, thereby permitting the guard to be removed from the bottom of the receptacle.

Access can be had to the contents of the bank by separating the members, or the coins can be withdrawn through the opening 19.

What I claim is—

1. A toy bank comprising separable members; means for securing said members together, a removable guard arranged to prevent access to said means for securing said members together and means for locking said guard in its operative position.

2. A bank comprising separable members, means for securing said members together, ridges formed on the interior surface of said bank and having openings in line with each other, a plate supported between said ridges and provided with an opening, a lug formed on said plate, a guard arranged to prevent access to said means for securing said members together, a shaft secured to said guard and arranged to extend through the opening in said plate and a tumbler arranged on the end of said shaft so as to come in contact with the lug on said plate when said guard is rotated.

3. A toy bank comprising separable members, ridges arranged on the interior surface of said bank and having openings in line with each other, a plate supported between said

ridges and having an opening arranged to be brought into registration with the openings in said ridges, a lug formed on said plate, a guard having a flange arranged to embrace a portion of said members, a shaft secured to said guard and arranged to extend through the opening in said plate and a tumbler secured to said shaft and arranged to come in contact with the lug on said plate when said guard is rotated for the purpose set forth.

4. A bank comprising two separable members, means for securing said members together at one end, lugs formed on the exterior surface of said members, a clip arranged to embrace said lugs, a guard arranged over said clip and means for locking said guard to said bank.

5. A bank comprising two separable members, means for securing said members together at one end, lugs arranged on said members, a clip arranged to embrace said lugs, annular ridges formed on the interior surface of said bank and having openings in line with each other, a plate supported between said ridges and having an opening arranged to be brought into registration with the openings in said ridges, a lug formed on said plate, a guard, a shaft secured to said guard and arranged to extend through said opening in said plate and a tumbler secured to said shaft and arranged to come in contact with the lug on said plate when said guard is rotated, substantially as described and for the purpose set forth.

6. A bank comprising a closed receptacle provided with a coin-receiving slot and having lugs formed on its interior surface at opposite sides and extending at a right angle to said slots to serve as deflectors for turning the coins transversely of the slot when the bank is tipped so as to bring the coins in proximity to the slot.

7. A bank comprising a coin-receptacle having an opening, ridges formed on the interior surface of said bank adjacent to the opening in the receptacle and having openings in line with each other, a plate supported between said ridges and having an opening arranged to be brought into registration with the openings in said ridges, a guard, a shaft secured to said guard and arranged to extend through said opening in said plate, a tumbler secured to said shaft and means for causing said tumbler to rotate said plate when said guard is rotated.

In testimony whereof I sign the foregoing specification, in the presence of two witnesses, this 22d day of June, 1904, at Cleveland, Ohio.

WILLIAM J. SOMERWILL.

Witnesses:

VICTOR C. LYNCH,
G. M. HAYES.